



**OPERATOR'S MANUAL**  
**TRAILER**  
**MODEL #ST4096T**

# TABLE OF CONTENTS

## OPERATOR'S MANUAL

Safety Alerts	1
General Safety	2
Warning	3
Read Before Towing Trailer	4
Tie Down Straps	5
Side Standards	6
Electric Straps	7
Lubricating	8
Specifications	9
Warranty Sheet	10

# EQUIPMENT SAFETY

## Safety Alerts

This hazard alert sign  appears in this manual. When you see this sign, carefully read what it says. **YOUR SAFETY IS AT STAKE.**

You will see the hazard alert sign with these words: **DANGER, WARNING, and CAUTION.**

### **DANGER**

Indicates an imminently hazardous situation which, if not avoided, will result in death or serious injury.

### **WARNING**

Indicates a potentially hazardous situation which, if not avoided, could result in death or serious injury.

### **CAUTION**

Indicates a hazardous situation which, if not avoided, may result in minor or moderate injury.

In this manual you should look for two other words: **NOTICE** and **IMPORTANT**.

**NOTICE:** can keep you from doing something that might damage the machine or someone's property. It may also be used to alert against unsafe practices.

**IMPORTANT:** can help you do a better job or make your job easier in some way.

## Read and Understand

Do not operate this equipment until you have carefully read, and understand the "Safety" and "Operation" sections of this manual, and all other equipment manuals that will be used with it.

Your safety and the safety of others depends upon care and judgment in the operation of this equipment.

Follow all applicable federal, state, local, and industry specific regulations.

We cannot anticipate every possible circumstance that might involve a potential hazard. The warnings in this manual and on the machine are therefore not all inclusive. You must satisfy yourself that a procedure, tool, work method, or operating technique is safe for you and others. You should also ensure that the machine will not be damaged or made unsafe by the method of operation or maintenance you choose.



# EQUIPMENT SAFETY

## General Safety

Safety is important. Report anything unusual that you notice during set up or operation.

**LISTEN** for thumps, bumps, rattles, squeals, air leaks, or unusual sounds.

**SMELL** odors like burning insulation, hot metal, burning rubber, hot oil, or natural gas.

**FEEL** any changes in the way the equipment operates.

**SEE** problems with wiring and cables, hydraulic connections, or other equipment.

**REPORT** anything you see, feel, smell, or hear that is different from what you expect, or that you think may be unsafe.



## Wear Safety Equipment

Wear a hard hat, safety shoes, safety glasses, and other applicable personal protective equipment.

Remove jewelry and rings, and do not wear loose-fitting clothing or long hair that could catch on controls or moving machinery.





**WARNING**



**STAND CLEAR  
WHEN OPERATING.  
15 FEET MINIMUM**

# TRANSPORTING

## ***Read Before Towing Trailer***

Never tow a trailer before you check to be sure of the following:

Check to assure brakes are operating.

Coupler and hitch are the right size.

Coupler and safety chains are safely secured to hitch.

Trailer jack is in the raised position.

Check all fasteners for proper tightness.

Wheel lug nuts are properly tightened.

Wheel bearings are properly adjusted and maintained.

Load is within maximum load carrying capacity.  
Tires are properly inflated.

All trailer lighting is working properly.

Following all federal, state, local and industry standards

Break away switch cable is attached to tow vehicle.



**PIN MUST ALWAYS BE FULLY INSERTED INTO BREAKAWAY SWITCH. REMOVING PIN (AS SHOWN) WILL ACTIVATE BRAKES, & MAY DAMAGE TIRES, BRAKES, BATTERY, WIRING, & OTHER PARTS.**



# TIE DOWN STRAPS

**Place Handle Bar  
in the Hole to  
Tighten Straps**



# SIDE STANDARDS

**Pull Pin to Lower  
Side Standards**





# ELECTRIC BRAKES

This trailer is equipped with electric brakes. To operate, the tow vehicle must be equipped with an electric brake controller.

**To Maintain:**

Check to be sure all electrical connections are good and there are no worn or broken wires.



# MAINTENANCE

## Lubrication

Check axles for grease.  
Follow manufacturer's  
recommendations.

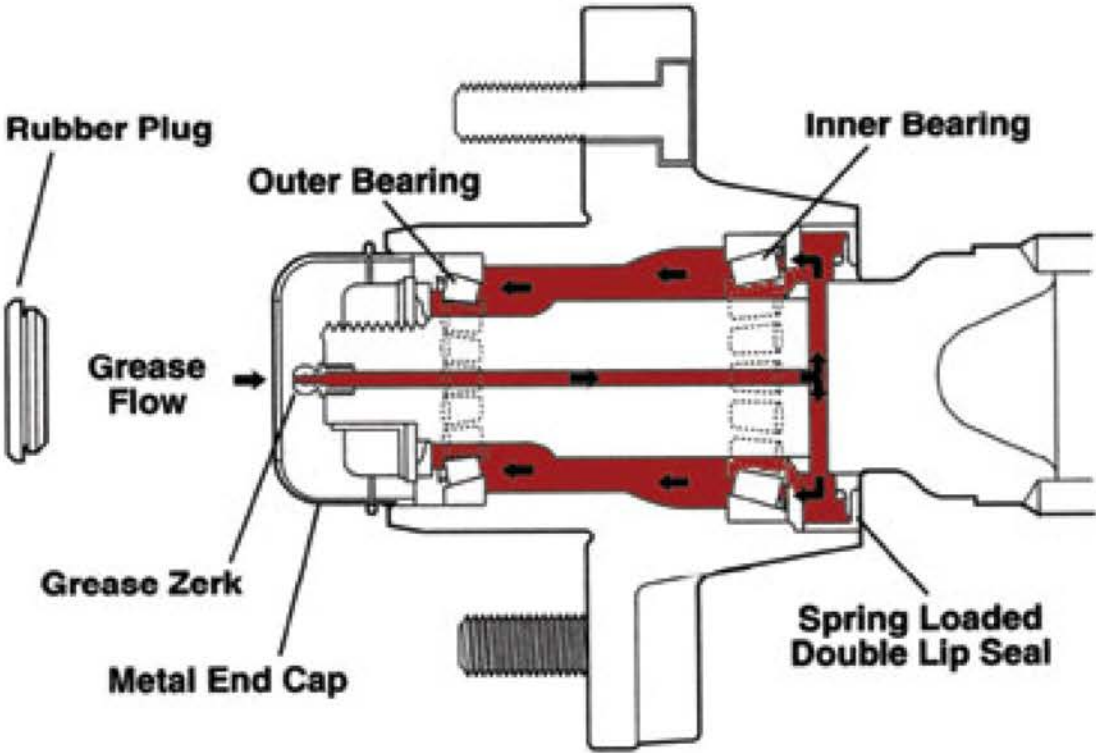



# MODEL: ST4096T

## SPECIFICATIONS

### DESCRIPTION

MODEL - ST4096T  
GVWR - 14,000 lbs.  
Empty Weight - 4,650 lbs.  
Carrying Capacity - 9,350 lbs.  
Overall Length - 46 ft. 6 in.  
Overall Width - 8 ft. 5 in.  
Overall Height - 5 ft. 7 in.  
Hauls up to 40' Lengths of Pipe

### RUNNING GEAR

Single Axle - 7,000 lbs.  
Brakes - Electric (All Wheels)  
Tires - ST235/80R16 LRE  
Wheels - 16 x 6 8 Bolt Mod  
Suspension - Slipper Leaf Spring

### FRAME

Main Frame - 10" Channel  
Head Board  
4 Heavy Duty 4" Straps  
4 Heavy Duty Winches w/ Winch Bar Welded On  
Tongue - Adjustable Height Pintle Eye  
Fenders - 12 ga.  
Jack - 12,000 lbs. Drop Foot

### ELECTRICAL

Plug - 7 RV Molded Plug  
Wiring - Enclosed in Tube with Junction Box  
Lights - Protected Standard LED

### SAFETY

Chains - 3/8" with Heavy Duty Hook & Safety Latch  
Breakaway - Battery, Battery Box and Switch  
Decals - Warning Decals and Reflective Tape

### INCLUDED ACCESSORIES

Toolbox - Black Aluminum Diamond Plate

### FINISH

Polyurethane Enamel



## Sweetwater Metal Products “Limited One (1) Year Warranty”

Sweetwater Metal Products – Sweetwater, TN 37874-3055, provides the following limited one (1) year warranty on products manufactured by it to the purchaser of such products and to any person to whom such product is transferred during the duration of this warranty.

The warrantor’s obligation shall be limited to repairing or replacing at the factory in Sweetwater, TN 37874, any part or parts which shall within the one (1) year period hereinafter specified be returned to it with transportation prepaid and which upon examination by Sweetwater Metal Products shows to have been defective. This warranty shall not apply if:

- (A) The product has been altered, repaired or modified outside the warrantor’s factory in any way that would adversely affect its operation.
- (B) The product has been subjected to misuse or damage while in the possession of the purchaser or any person to whom the product was transferred by the purchaser or was installed or operated other than in accordance with the manufacturer’s operating instructions.
- (C) The product was used with accessories not recommended by Sweetwater Metal Products or for loads in excess of those listed as rated for the product.

The one (1) year limited warranty period shall commence with the date the product is sold to the purchaser by the dealer or, if this date cannot be established, the date the product was sold by Sweetwater Metal Products.

The implied warranties of merchantability and fitness for particular purpose are limited to the duration of this warranty – one (1) year – after said one (1) year, Sweetwater Metal Products expressly disclaims any warranty of merchantability or fitness for any particular purpose.

Purchase or other acceptance of the product by the claimant shall be on the condition and agreement that Sweetwater Metal Products shall not be liable for incidental or consequential damages of any kind.

Sweetwater Metal Products shall not be liable for paint damage due to rock chipping.

Tires are not included under the one (1) year warranty and should the purchaser find them unsatisfactory, should make a claim directly to the tire manufacturer.

To make a claim under this warranty, write directly to Sweetwater Metal Products – 127 Industrial Park Rd – Sweetwater, TN 37874-3055, identifying the product and giving its location. Return instructions will be provided by the company. Sweetwater Metal Products will make its best efforts to repair or replace the products, if found to be defective within the terms of this warranty, within sixty (60) days after return of the product to the company.

In order to validate warranty, fill out the accompanying warranty registration card and return with ten (10) days from the date of purchase.